



## 5055

### Wheel Loader

Maximum flexibility in everyday work.



The compact model of the 5 series is an all-wheel steer wheel loader and became known as the "550". The clearance width on this machine is under 1.58 m, so working in space-constrained environments is not a problem. The concept of the undivided frame provides excellent visibility of the front attachment area as well as the rear attachment area and simplifies the change of attachments immensely. The optionally available load stabilizer enables smooth and safe driving behavior even during handling operations, as vibrations of the loading equipment are damped.

**Versatility:** A flexible bucket volume from 0.55 m<sup>3</sup> to 1.1 m<sup>3</sup> depending on material density.

**Range:** The specially shaped loading system and the P-kinematics also allow unloading from the second row.

**Proven system:** The undivided frame and proven Kramer all-wheel steering ensure maximum payload even on uneven terrain.

**Visibility ratio:** The low approach of the Kramer loader provides perfect all-round visibility.

**Maneuverability:** A combination of 2,700 mm turning radius (outer edge of tire) realized by 2 x 38° steering angle and optimal stability.

## Technical Data

### Standard engine data

Engine manufacturer	Yanmar
Drive output	34.3 kW
Drive output	46 PS
Cylinder capacity	2,190 cm <sup>3</sup>
Exhaust aftertreatment	DOC / DPF

### Weights

Bucket capacity (standard bucket)	0.55 m <sup>3</sup>
Operating weight	3,200 - 4,300 kg
Payload (S=1.25)	1,600 kg
Lift capacity (max.)	32.5 kN
Tipping load (standard bucket)	1,980 kg
Tipping load (pallet fork)	2,000 kg

### Filling levels

Tank capacity for fuel	60 l
------------------------	------

Tank capacity for hydraulic oil 58 l

### Drive system

Travel speed Standard	0-20 km/h
Travel speed Option 1	0-30 km/h

### Hydraulic system

Work hydraulics discharge volume (max.)	56 l/min
---	----------

### Kinematics

Kinematics type	P
-----------------	---

### Steering

Steering angle max.	38 degree
---------------------	-----------

### Noise characteristic values

Guaranteed sound power level LwA (operator's canopy)	101 dB(A)
Measured sound power level LwA	100.3 dB(A)
Sound pressure level at the operator's ear	79 dB(A)

## Dimensions

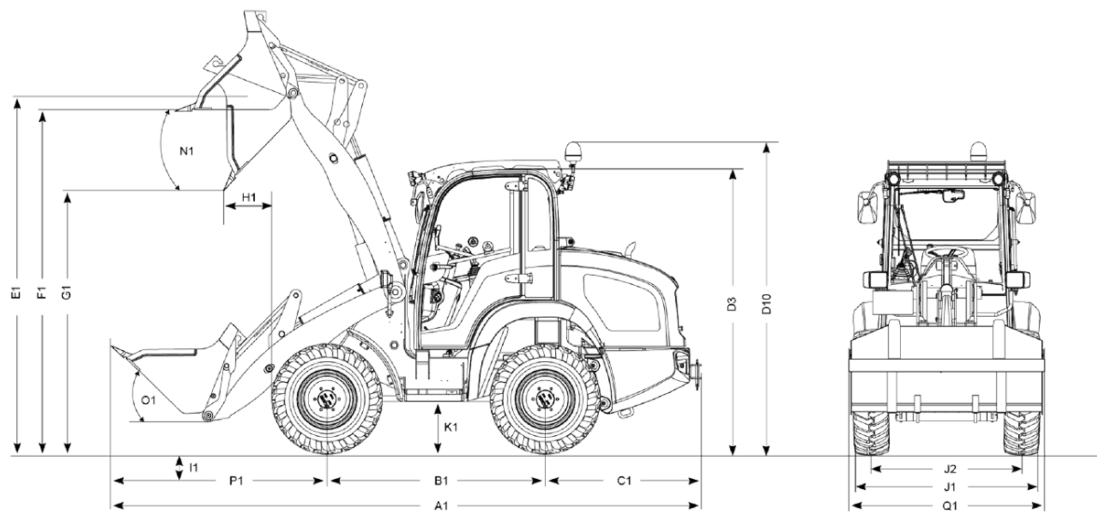

A1	Total length with standard attachment	4,950 mm
A2	Total length with standard attachment / extended loading system	5,140 mm
B1	Wheel base center	1,850 mm
C1	Rear overhang	1,320 mm
D3	Height with cab	2,390 mm
D5	Height of cab with protective grille	2,470 mm
D10	Total height with rotating beacon	2,390 mm
E1	Max. height blade pivot point	3,050 mm
E2	Max. height of hinge pin height / extended loading system	3,300 mm
F1	Load-over height	2,750 mm
F2	Load-over height / extended loading system	3,150 mm
G1	Dumping height	2,310 mm
G2	Dumping height / extended loading system	2,650 mm
H1	Dumping width	315 mm
H2	Dumping range / extended loading system	410 mm
I1	Digging depth	55 mm
J1	Total width	1,590 mm
J2	Track width	1,262 mm
K1	Ground clearance	280 mm
L1	Turning radius outer edge wheels	2,700 mm
M1	Steering angle	38 °
M2	Swing angle	16 °
N1	Dumping angle at max. lifting height	45 °
O1	Dumping angle at ground level	45 °
P1	Distance center front axle to tooth tip	1,780 mm
Q1	Bucket width	1,650 mm
R1	Stacking height	2,950 mm